

Assembly guide

Cupboard Pull out Basket:

Component parts

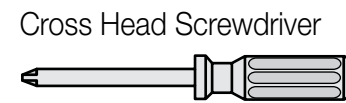
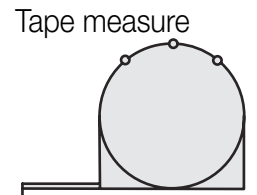
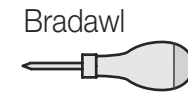
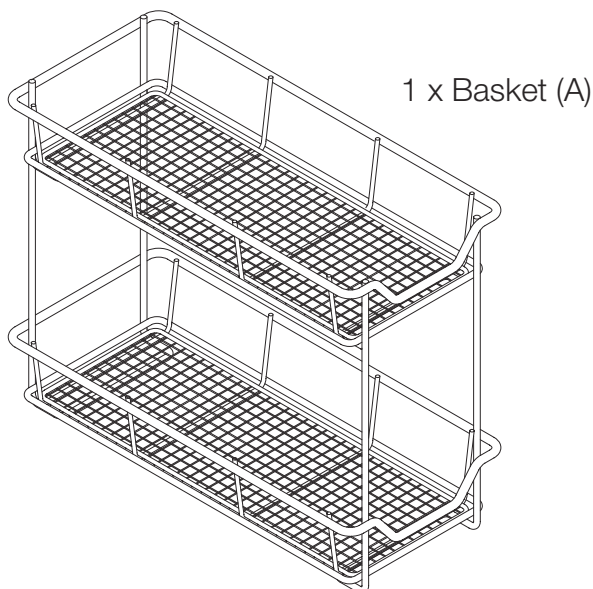
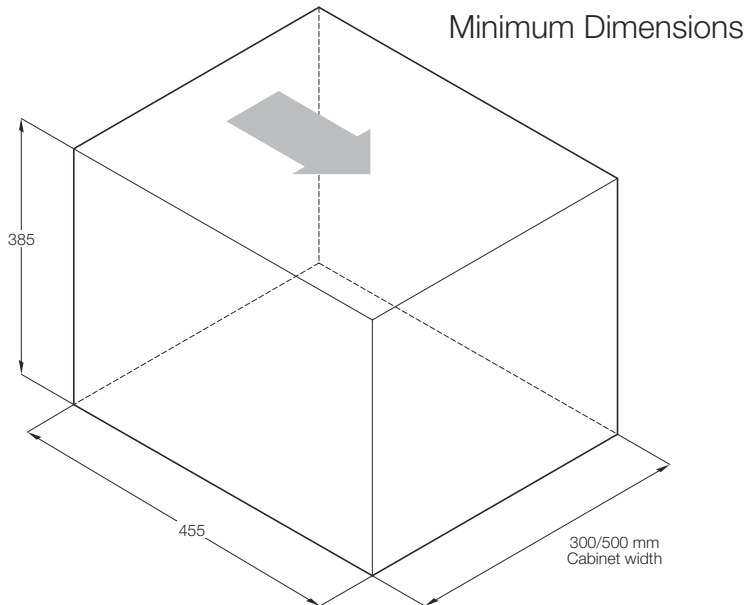

Did you know Häfele also supply tools to the trade and industry?
See www.hafele.co.uk for more information.

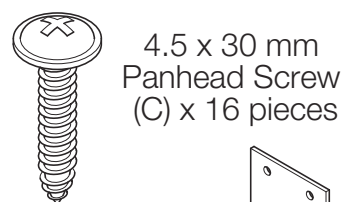

2 mm Spacer
(D) x 32 pieces



- Make sure all the components are included before you start.
- The number for technical support is at the bottom of the page.
- Don't rush!
- Read the instructions first.
- Assemble in the stages shown.
- Keep the fittings together to avoid loss.
- Have fun.

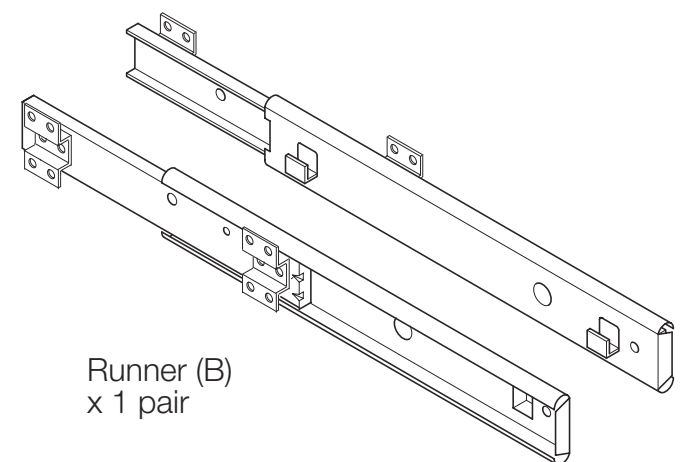

1 Using the runner drilling pattern shown in diagram 1, fix the runner (B) and required additional 2 mm spacers (D) using 16 x 4.5 x 30 mm pan head screws (C) to the internal side of the carcass with the bottom runner fixing point a minimum of 10 mm up from the floor level of the cabinet.

Board thickness	Total no. of spacers to be used on on each side of the cabinet
15 mm	8
16 mm	7/8
18 mm	6/7
19 mm	6

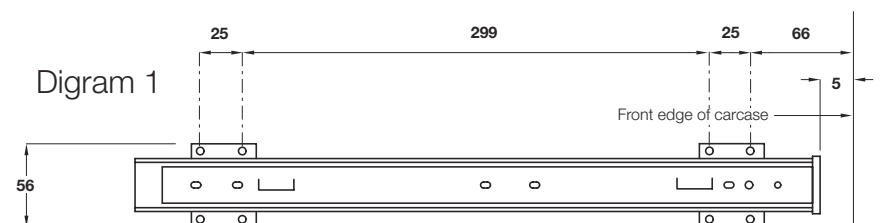

2 Using the bottom ring, clip basket (A) into the 2 lugs on each side of runner (B), as shown in diagram 3.

